

---

## 0199 - 99 - 12091/10 EN

This Circular supersedes:  
0199-99-12091/09

---



## Specification for Coolant

Valid for: **CG132, CG170, CG260**

The 10th replacement is made because of:

- Updating the approved cooling system protection agents

Contents:

- General information
- Cooling systems
- Cooling system protection agents
  - Chemical corrosion protection agents
  - Antifreezes with corrosion inhibitors
- Preparing the coolant
  - Cooling water properties
  - Addition of chemical corrosion protection agents
  - Addition of antifreezes
- Limit values of the coolant
  - Engine circuit
  - Heating circuit
- Testing and replacing the coolant
- Cleaning the cooling system
- Disposal of the coolant
- Released cooling system protection agents
  - Chemical corrosion protection agents
  - Antifreezes with corrosion inhibitors

---

Imprint:  
MWM GmbH  
Servicedokumentation  
M. Granson  
Carl-Benz-Str. 1  
D-68167 Mannheim  
Phone: +49 621 384-8455  
Fax: +49 621 384-8841  
www.mwm.net  
Date:  
2013-07-02

Note:  
The part numbers stated in this documentation are not subject to the modification service.  
For identifying spare parts, the spare part documentation has to be referred to.

Copies to:  
- TR  
- According to SIT 17010



**0199 - 99 - 12091/10 EN**

**General information**



**Risk of destruction of components**

Due to non-approved cooling system protection agents

- The engine or system may only be operated with the approved cooling system protection agents

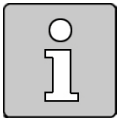

The owner is solely responsible for observing the coolant oil specification described.

The manufacturer accepts no liability for damage caused by the use of non-approved cooling system protection agents or by improper operation.

The owner is responsible for observance of the respective national legal provisions.

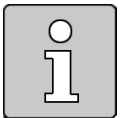

All the data in this Technical Bulletin corresponds to the latest state of knowledge. If you have any queries, please contact your Caterpillar dealer.

The cooling water referred to in this bulletin is water with suitable properties for preparing the coolant ⇒ see chapter Cooling water properties.

The coolant consists of cooling water with the admixture of cooling system protection agents ⇒ see chapter Preparing the coolant.

The coolant must be suitable for all the components in the engine (different metals, elastomers) and meet the different requirements in the engine cooling circuit, heating circuit and mixture cooling circuit or charge air cooling circuit. Appropriate properties of the coolant are necessary to avoid damage especially to the exhaust heat exchanger due to poor quality of the coolant ⇒ see chapter Limit values of the coolant.

The products which are released as cooling system protection agents are listed in the chapter Cooling system protection agents.

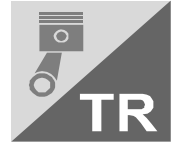

### Cooling systems

Cooling systems are designed differently depending on the requirements.

The designs of cooling circuits are shown in simplified terms below:

A) Cooling system without heat utilization:

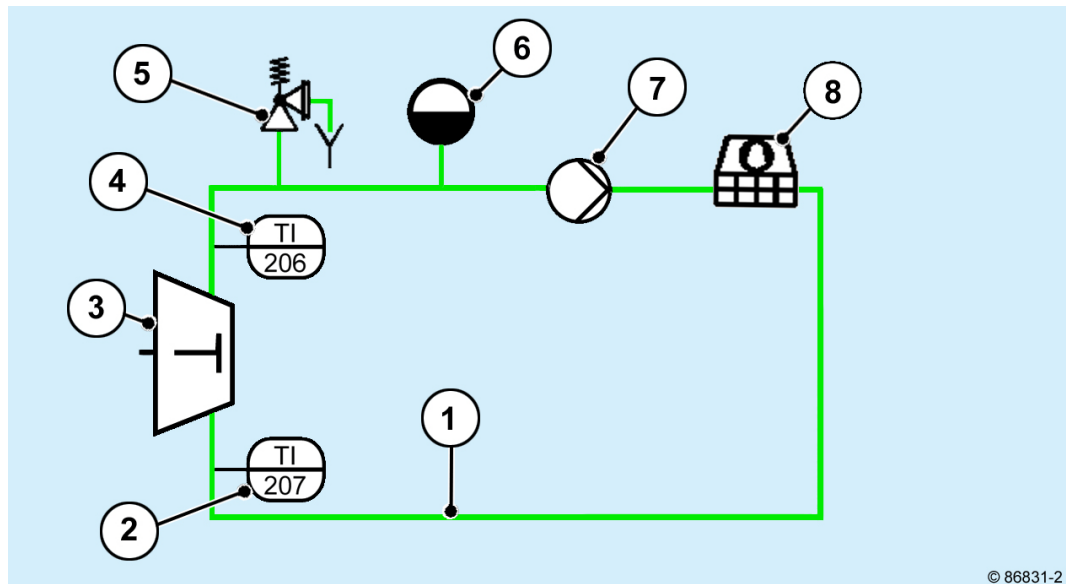

- 1 Engine cooling circuit
- 2 Temperature sensor at engine inlet
- 3 Engine
- 4 Temperature sensor at engine outlet
- 5 Safety valve
- 6 Diaphragm expansion vessel
- 7 Coolant pump
- 8 Coolers



0199 - 99 - 12091/10 EN

B) Cooling system with exhaust heat exchanger in the heating circuit:

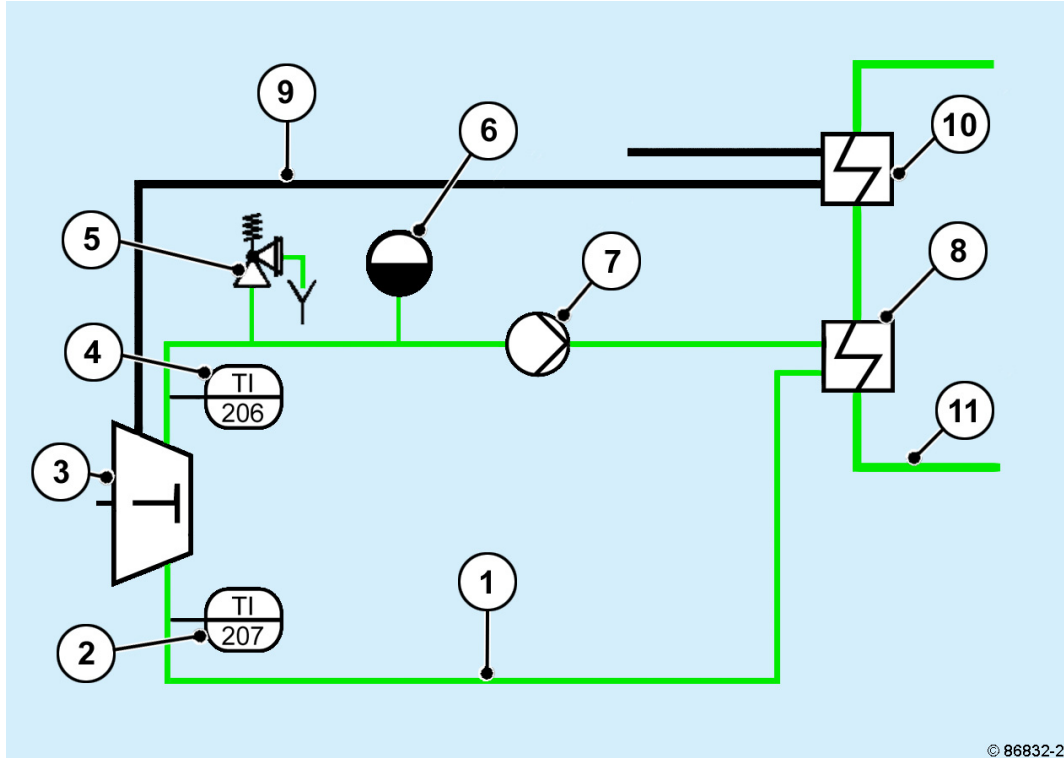

© 86832-2

- 1 Engine cooling circuit
- 2 Temperature sensor at engine inlet
- 3 Engine
- 4 Temperature sensor at engine outlet
- 5 Safety valve
- 6 Diaphragm expansion vessel
- 7 Coolant pump
- 8 Heat exchanger
- 9 Exhaust gas
- 10 Exhaust heat exchanger
- 11 Heating circuit

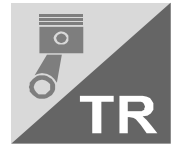

C) Cooling system with exhaust heat exchanger in the engine cooling circuit:

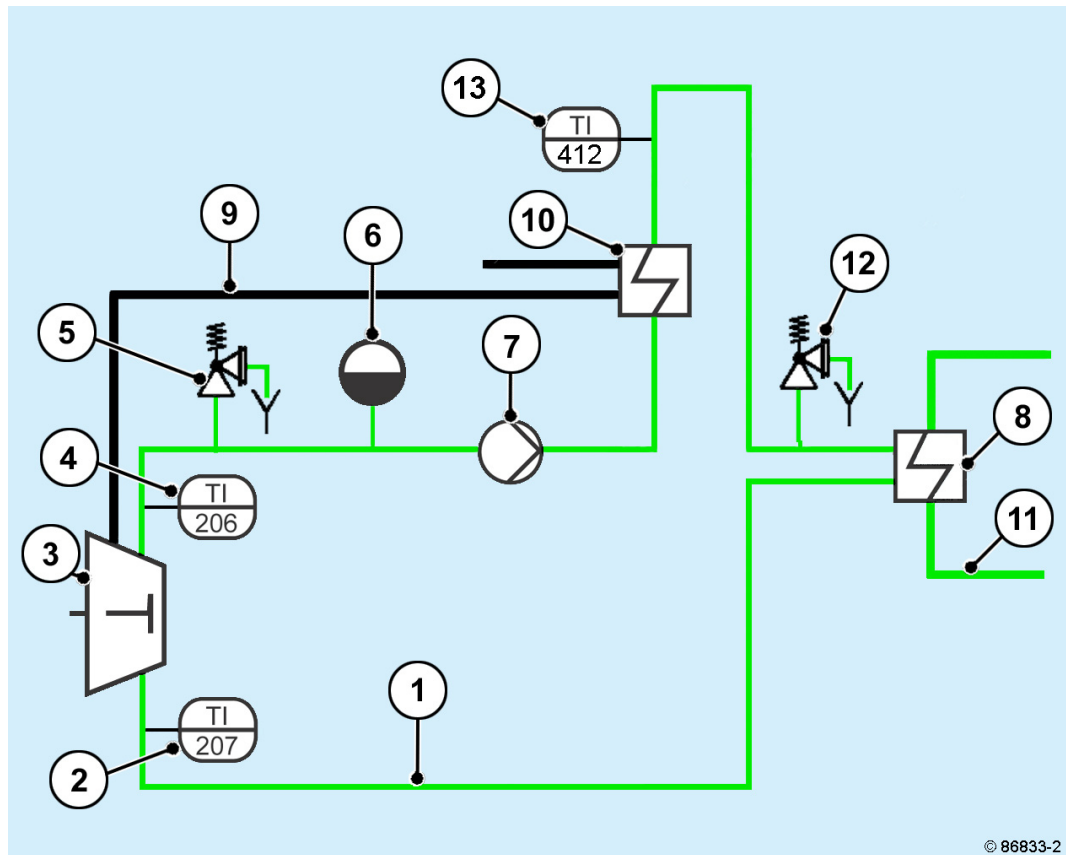

© 86833-2

- 1 Engine cooling circuit
- 2 Temperature sensor at engine inlet
- 3 Engine
- 4 Temperature sensor at engine outlet
- 5 Safety valve
- 6 Diaphragm expansion vessel
- 7 Coolant pump
- 8 Heat exchanger
- 9 Exhaust gas
- 10 Exhaust heat exchanger
- 11 Heating circuit
- 12 Safety valve
- 13 Temperature sensor at exhaust heat exchanger outlet



**0199 - 99 - 12091/10 EN**

**Cooling system protection agents**



**Risk of destruction of components**

Cooling system protection agents which are made from different raw products may not be mixed.

- When changing over the cooling circuit to a different product, the compatibility of the products must be ensured. If necessary, the cooling system must be purged before conversion



**WARNING**

**Danger of poisoning**

Due to the mixing of agents containing amine and nitrite  
Severe injury or death can result

- Do not mix agents containing amine and nitrite, as carcinogenic nitrosamines can result from this

In the system protection agents a distinction is made between:

- Chemical corrosion protection agents which form a protective film on metal surfaces by chemical reactions and therefore prevent damage such as corrosion and cavitation on the cooling system, but do not act as an antifreeze
- Antifreezes with corrosion inhibitors which avoid freezing of the coolant and also offer corrosion protection

**Chemical corrosion protection agents**

Chemical corrosion protection agents have the following properties:

Properties	
Corrosion protection	good
Cavitation protection	satisfactory
Antifreeze	none
Care	low
Operational safety	good

Chemical corrosion protection agents that contain silicates can damage the mechanical seals of the coolant pumps. These agents are therefore not listed under the approved products.

**0199 - 99 - 12091/10 EN**

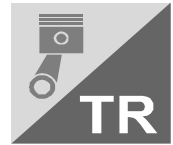

**Antifreezes with corrosion inhibitors**

When using antifreezes the heat transition value (heat capacity and heat conductance) of the coolant is reduced.

Make sure that the cooling system is designed for this.

Antifreezes with corrosion inhibitors have the following properties:

<b>Properties</b>	
Corrosion protection	good
Cavitation protection	satisfactory
Antifreeze	depending on the mixing ratio
Care	low
Operational safety	good

Antifreezes with corrosion protection are used when sub-zero ambient temperatures can occur.



**0199 - 99 - 12091/10 EN**

**Preparing the coolant**

The coolant is prepared by adding a chemical corrosion protection agent or an antifreeze with corrosion inhibitors to the cooling water.

**Cooling water properties**



**Risk of destruction of components**

- Sea water, river water, brackish water or industrial waste water is unsuitable as cooling water for engines and systems
- Depending on the structure of the cooling circuit, the following limit values must be observed when preparing the cooling water

Information about the properties of the water can be provided by the local waterworks or can be determined with the test set for cooling water or in a suitable chemical laboratory.

Sampling and water analysis must be carried out with great care and accuracy.

Only clean and odorless water with the following properties may be used as a cooling water for engines and systems:

**Limit values of the cooling water for cooling systems A and B without exhaust heat exchanger**

pH value at 25 °C	6.5 to 8.5
Chloride ion content	maximum 100 mg/L
Sulfate ion content	maximum 100 mg/L
Total hardness	3 to 12 °dH
Carbonate hardness proportion of the total hardness	minimum 3 °dH

**Limit values of the cooling water for cooling system C with exhaust heat exchanger**

pH value at 25 °C	6.5 to 8.5
Chloride ion content	less than 20 mg/L
Sulfate ion content	maximum 100 mg/L
Total hardness	less than 1 °dH
Carbonate hardness proportion of the total hardness	less than 1 °dH



---

**0199 - 99 - 12091/10 EN**

---

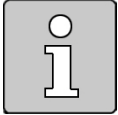

The water hardness is specified in mol per liter or, for low concentrations, in millimol per liter (mmol/L).

The unit degree German hardness (°dH) is still the most commonly used in Germany.

The degree German hardness (°dH) is converted into mmol/L as follows:

$$1 \text{ °dH} = 0.178 \text{ mmol/L}, \quad 1 \text{ mmol/L} = 5.6 \text{ °dH}$$

---

In case of deviation from the limit values listed above, the cooling water is prepared as follows:

- pH value too low:  
Addition of diluted sodium or potassium lye.  
It is advisable to make small sample mixtures before adding.
- Total hardness and/or carbonate hardness too low:  
Mixing with harder water  
Harder water is usually available in the form of drinking water (city mains water).
- Total hardness, chloride and/or sulfates too high:  
Mixing with softened water  
Softened water is distilled water or water treated with an ion exchanger.

Another water analysis must be carried out after preparing the cooling water.



**0199 - 99 - 12091/10 EN**

**Addition of chemical corrosion protection agents**



**Risk of destruction of components**

- An under-concentration of the chemical corrosion protection agent has a damaging effect on the cooling system, especially aluminum parts
- Observe the correct dosing of the chemical corrosion protection agent

The corrosion protection agent is mixed with the cooling water first and then filled into the cooling system as described in job card **B 9-0-4 Emptying and filling the cooling system** in the appropriate operating manual.

The necessary concentrations of the chemical corrosion protection agent in cooling circuits are determined according to the specifications of the manufacturer or supplier.

**Addition of antifreezes with corrosion inhibitors**

The antifreeze is mixed with the cooling water first and then filled into the cooling system as described in job card **B 9-0-4 Emptying and filling the cooling system** in the appropriate operating manual.

The coolant must be inspected for the necessary freezing protection after preparation.

The freezing protection of the antifreeze depends on the mixing ratio with the cooling water:

Antifreeze	Cooling water	Freezing protection up to
35%	65%	-23 °C
40%	60%	-29 °C
45%	55%	-35 °C
50%	50%	-40 °C

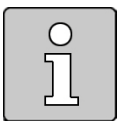

The concentration of the antifreeze must be at least 35% to ensure an adequate corrosion protection.

When using an antifreeze with corrosion inhibitors for corrosion protection the antifreeze must stay in the cooling system even at temperatures above freezing point.



**Risk of destruction of components**

- Pure antifreeze may not be filled into the cooling system
- Please contact your Caterpillar dealer if antifreeze below -40 °C is required
- The limits values listed for the coolant must be observed

**0199 - 99 - 12091/10 EN**



**Limit values of the coolant**

**Engine cooling circuit**

**Limit values of the coolant for cooling systems A and B without exhaust heat exchanger in the engine cooling circuit**

If the specifications for cooling water quality of the cooling system protection agent are complied with, the quality of the coolant is sufficient.

**Limit values of the coolant for cooling system C with exhaust heat exchanger in the engine cooling circuit**

pH value at 25 °C	7.5 to 8.5
Chloride ion content	less than 20 mg/L
Total hardness	less than 1 °dH
Filling volumes	maximum 2 m <sup>3</sup>
Temperature at exhaust heat exchanger outlet	maximum 110 °C

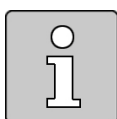

The filling volume is limited to 2 m<sup>3</sup> to avoid heat build-up deposits due to escaping carbonate at the limit surfaces of the exhaust heat exchanger.

**Heating circuit**



**Risk of destruction of components**

- The coolant, which is exclusively for use in heating circuits of iron materials, is unsuitable for the engine cooling circuit
- The manufacturer will not be liable for damage caused by using this coolant in the engine cooling circuit

**Limit values of the coolant for the heating circuit**

pH value at 25 °C	9 to 10.5
Electrical conductivity	less than 0.1 mS/cm
Oxygen (O <sub>2</sub> )	less than 0.05 mg/L
Chloride	less than 20 mg/L
Copper (Cu)	less than 0.05 mg/L
Total iron (Fe)	less than 0.05 mg/L
Phosphate (PO <sub>4</sub> )	5 to 10 mg/L
Earth alkalis	less than 0.02 mmol/L
Total hardness	less than 0.1 °dH



**0199 - 99 - 12091/10 EN**

**Testing and replacing the coolant**

The cooling system must be inspected and serviced at the specified intervals. This also includes inspecting the properties of the coolant and the concentrations of the cooling system protection agents in cooling systems as well as refilling and changing the coolant.

The cooling system protection agent in the coolant must be checked according to job card **B 9-1-1 Checking the percentage of corrosion protection agent or antifreeze in the coolant** in the appropriate operating manual.

When checking the chemical corrosion protection agents using a refractometer, the manufacturer's instructions for the conversion of %Brix to Vol.% must be observed.

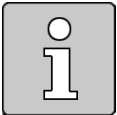

The specifications of the cooling system protection agent manufacturer must be observed when checking the coolant.

All inspections must be carried out according to the maintenance schedule and documented in the operation log.

The coolant must also be changed in the following circumstances:

- Penetration by water from outside
- Lubricating oil penetration
- Conspicuous turbidity due to corrosion residues or other suspended particles



**Risk of destruction of components**

Due to failure to comply with the information and specifications for the production and use of coolants.

- The same product must be used again when refilling the coolant
- The compatibility of the products must be checked if a product needs to be changed
- In case of incompatibility the entire cooling system must be cleaned thoroughly before changing the product
- The engine or system may only be operated with the approved cooling system protection agents

---

## 0199 - 99 - 12091/10 EN

---



### Cleaning the cooling system

The complete cooling system must be cleaned in the following circumstances:

- Contamination with dirt
- Lubricating oil penetration
- Penetration by water from outside
- Product change (incompatible products)
- Maintenance work

The coolant must be completely drained and purged with an approved cleaning agent.

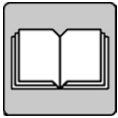

---

For more information on the cleaning agents, see

- Operating Manual ⇒ General ⇒ Operating media regulations
    - TR 0199-99-02147 Specification for auxiliary media
- 

### Disposal of the coolant

Coolant and cooling system protection agents must be disposed of properly according to the respective national, legal regulations and specifications of the manufacturer or supplier by a licensed disposal company.

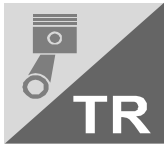
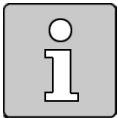

**0199 - 99 - 12091/10 EN**
**Released cooling system protection agents**

Some manufacturers provide ready mixtures for cooling systems. These mixtures can be used if they correspond to the relevant requirements.

**Chemical corrosion protection agents**

Valid for:	CG132, CG170, CG260
Addinol	Protect Extra
Aqua Concept	CORACON BL6
Arteco	Havoline XLI
Caltex	Delo XLI Corrosion Inhibitor
Caterpillar	ELI - Extended Life Inhibitor
Chevron	Delo XLI Corrosion Inhibitor
Texaco	Ursa XLI Corrosion Inhibitor Havoline Extended Life Corrosion Inhibitor (XLI)
Total	WT Supra

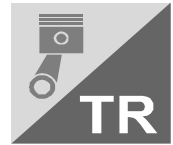
**0199 - 99 - 12091/10 EN**



**Antifreezes with corrosion inhibitors**



**Risk of destruction of components**

Due to failure to comply with the information and specifications for the production and use of coolants.

- Owing to different compositions of antifreezes with corrosion inhibitors, these are divided into product group 1 and 2
- Products of group 1 may not be used with products of group 2

<b>Valid for:</b>	<b>CG132, CG170, CG260</b>
<b>Product group 1</b>	
Aral	Antifreeze Extra
BASF	Glysantin G48 / Protect Plus
Castrol	Antifreeze NF
Classic	Kolda UE G48
Fuchs Europe	MAINTAIN FRICOFIN
INEOS	Napgel C2270/1
Mobil	Antifreeze Extra
OMV	Coolant plus
Shell	Glyco Shell
TOTAL	Glacelf MDX

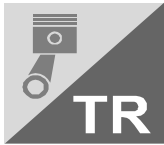

**0199 - 99 - 12091/10 EN**

**Product group 2**

Addinol

Antifreeze Extra

Aqua Concept

CORACON BF6

ARTECO

Havoline XLC

Havoline XLC-PG

Caltex

Extended Life Coolant

Caterpillar

ELC - Extended Life Coolant

Chevron/Texaco

Havoline Extended Life Coolant HELAC (without nitrite or molybdate)

Extended Life Coolant TELC (with nitrite and molybdate)

DELO Extended Life Coolant/Antifreeze PG

Fuchs

Maintain Fricofin LL

Gazpromneft

G-Energy Antifreeze SNF

Q8

Antifreeze Long Life

SWD Rheinol

Antifreeze GW-12 Concentrate

TOTAL

Glacelf CHP Supra

Glacelf Supra

**Service Information**

This document was created digitally and is valid without a signature.